



Construction

Pump casing with suction and delivery connections with the same diameter and on the same axis (in-line).

Materials:

Pump casing	Cast iron
Impeller	Stainless steel
Shaft	Stainless steel

Applications

For clean liquids, without abrasives, which are non-aggressive for the pump materials (contents of solids up to 0.2%).

For heating, conditioning, cooling and circulation plants.

For civil and industrial applications.

When low noise operation is required.

Operating conditions

Liquid temperature from -10 °C to +120 °C (in short-time duty up to +140 °C).

Ambient temperature up to 40 °C.

Maximum glycol quantity: 50% (Mixture with more than 20% glycol content require rechecking of the pumping data).

Maximum permissible working pressure 6/10 bar.

TYPE	Minimum suction pressure: bar		
	Temperature		
	50 °C	80 °C	110 °C
NCD 40	0,05	0,8	1,4
NCD 50	0,3	1	1,6
NCD 65	0,3	1	1,6
NCD 80	0,3	1	1,6

Motor

2-4-pole induction motor, 50 Hz.

Three adjustable speeds.

NCD: three-phase 230V or 400 V.

NCDM: single-phase 230 V.

Insulation class H.

Protection IP 43.

Operation

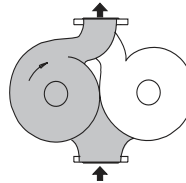

Single operation

Operation of a single pump choosed by the customer, with the second pump on stand-by

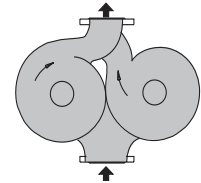

Double operation

Operation in parallel of the two pumps

Installation

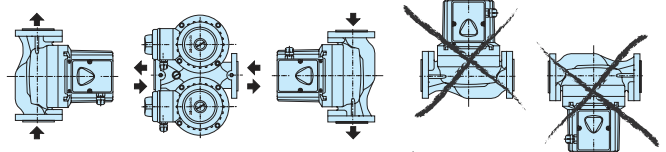

Cross section drawings

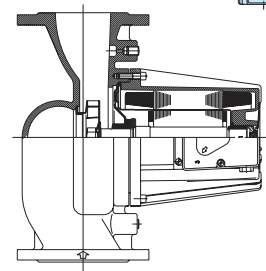

Designation

NC D (M) 4 40 - 60 / 250

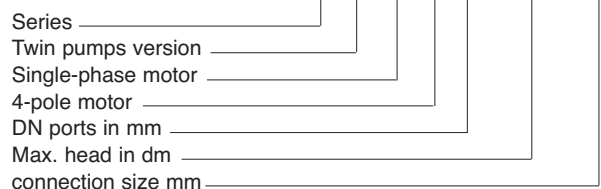

Coverage chart

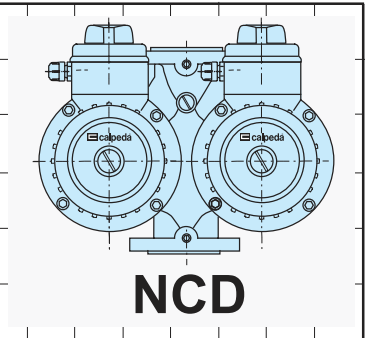
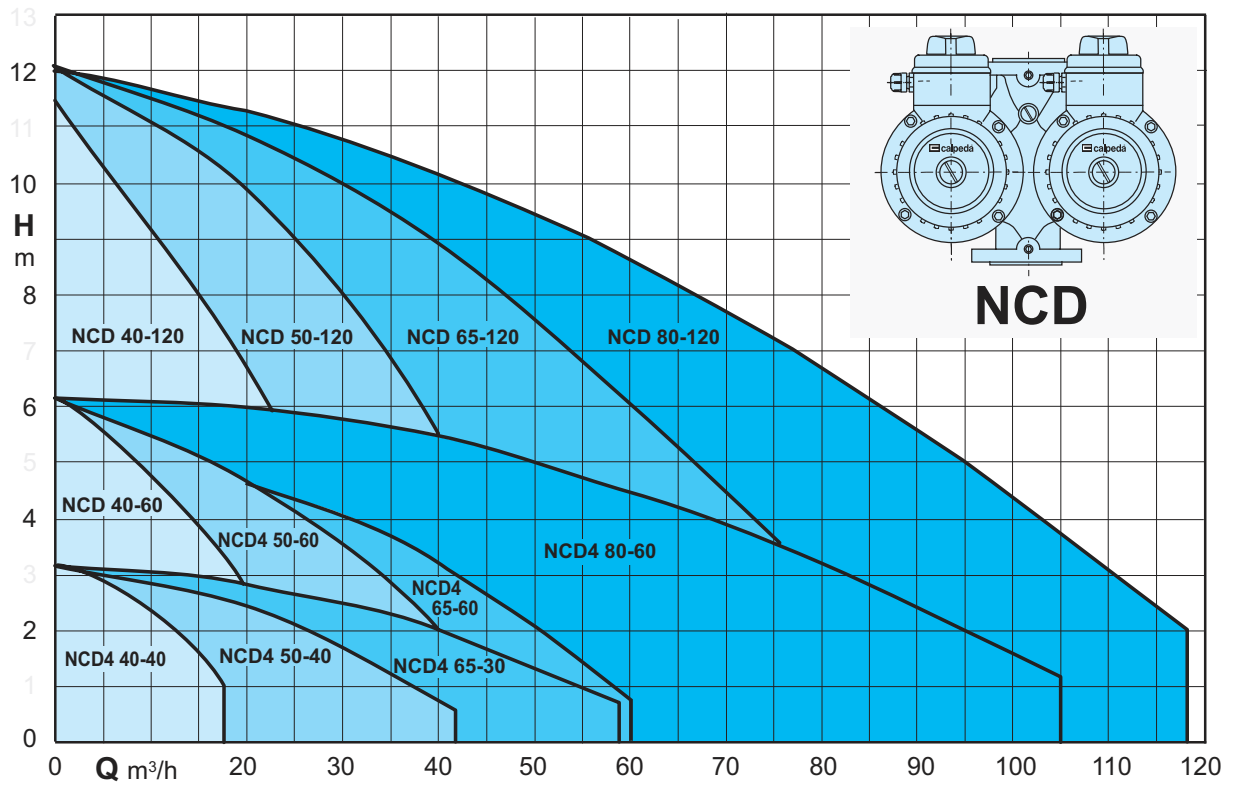

Tolerances according to ISO 9906, annex A.

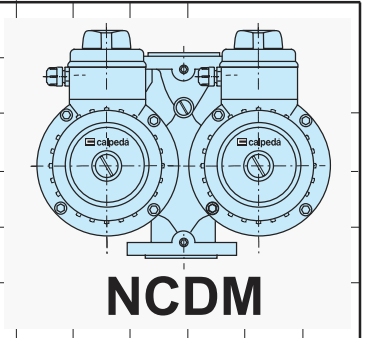
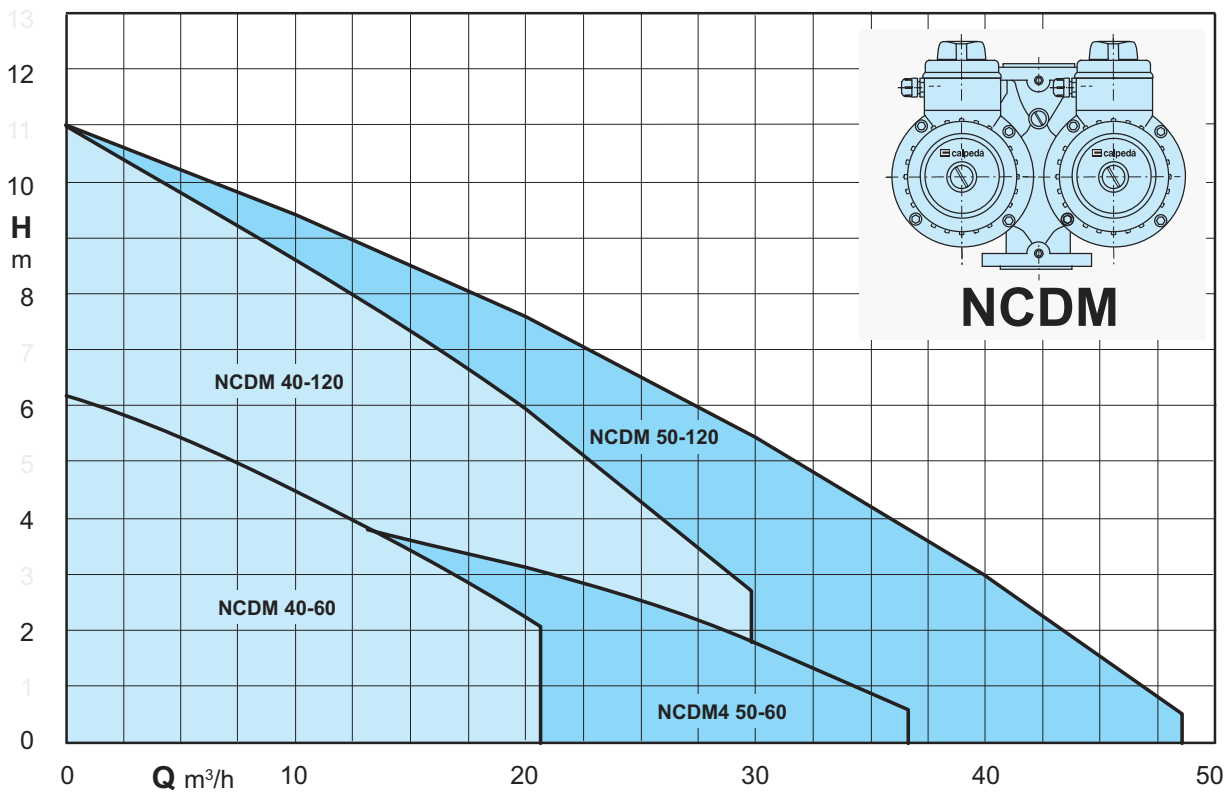

Tolerances according to ISO 9906, annex A.

Characteristic curves, dimensions and weights

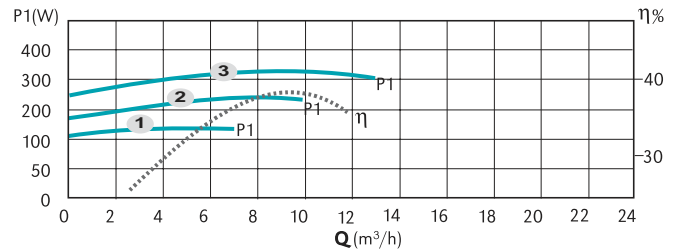
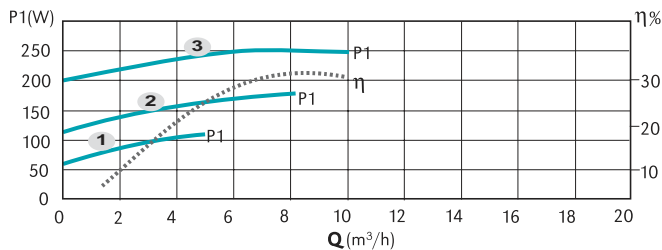
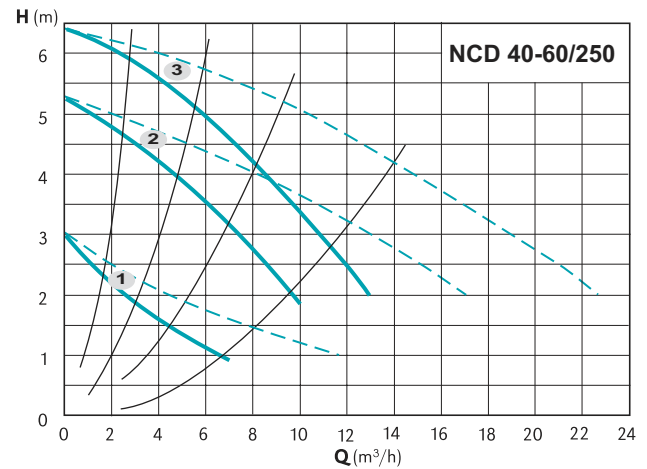
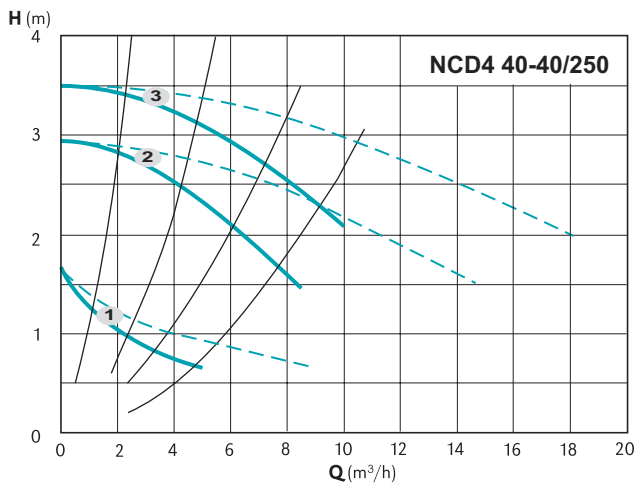

— Single operation
- - - Operation in parallel

— Single operation
- - - Operation in parallel

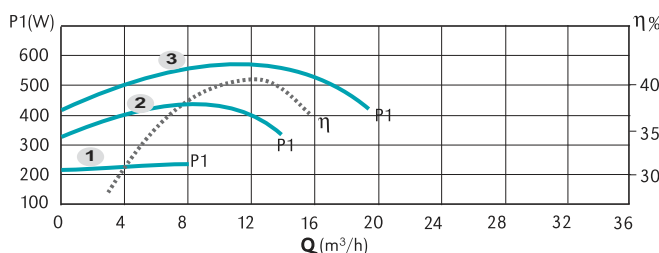
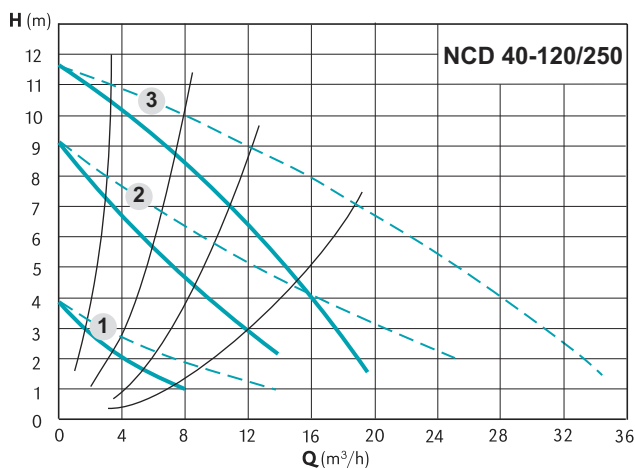

— Single operation
- - - Operation in parallel

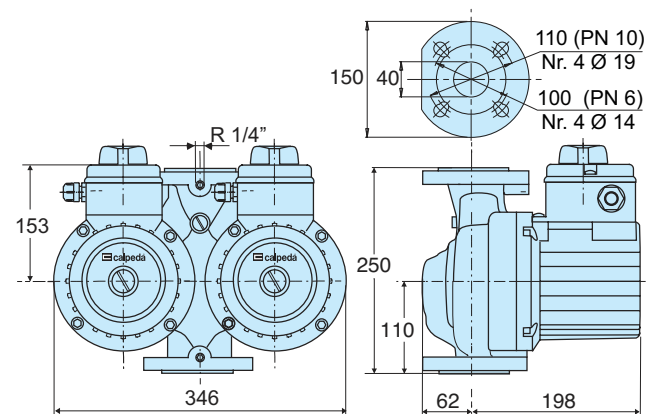

TYPE	DN	PN	N° Poli		Pos.	1/min	P1 (W)	3x 400 V [A]		[kg]
			2	4						
NCD4 40-40/250	40	6/10	✓		3	1440	240	0,76	34,0	
					2	1200	160	0,24		
					1	660	100	0,11		
NCD 40-60/250	40	6/10	✓		3	2790	320	0,74	35,0	
					2	2240	240	0,36		
					1	1440	140	0,18		
NCD 40-120/250	40	6/10	✓		3	2820	560	1,16	35,0	
					2	2200	400	0,64		
					1	1250	220	0,26		

Characteristic curves, dimensions and weights

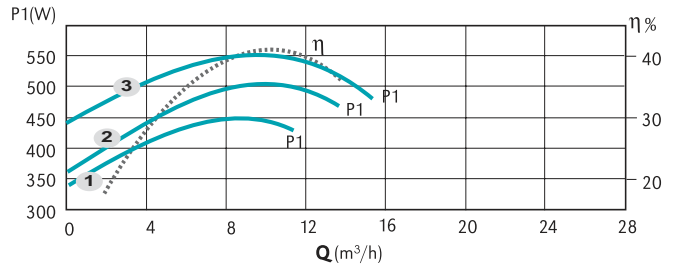
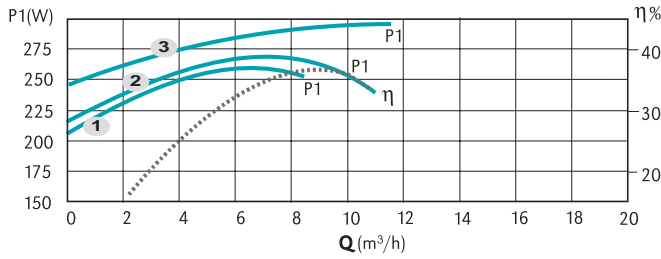
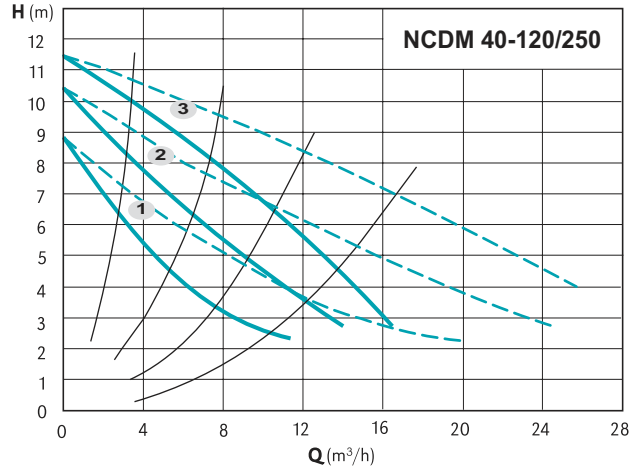
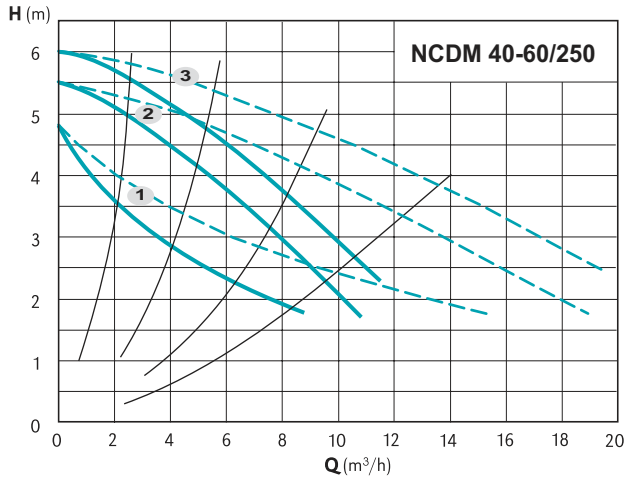

— Single operation
- - - Operation in parallel

— Single operation
- - - Operation in parallel

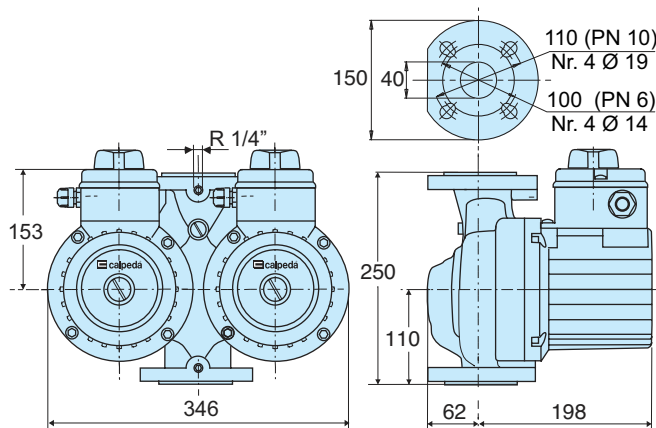

TYPE	DN	PN	N° Poli		Pos.	1/min	P1 (W)	1x 230 V [A]	[kg]
			2	4					
NCDM 40-60/250	40	6/10	✓		3	2690	285	1,20	35,0
					2	2360	245	1,18	
					1	1820	225	1,15	
NCDM 40-120/250	40	6/10	✓		3	2755	550	2,35	35,0
					2	2100	475	2,30	
					1	1270	355	1,85	

Characteristic curves, dimensions and weights

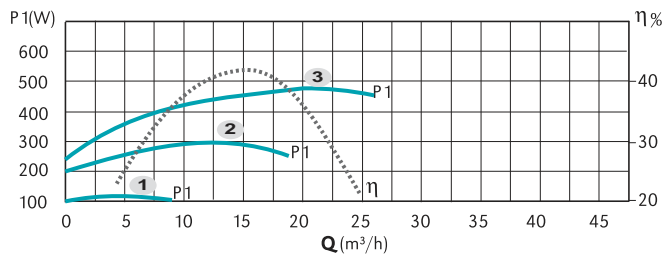
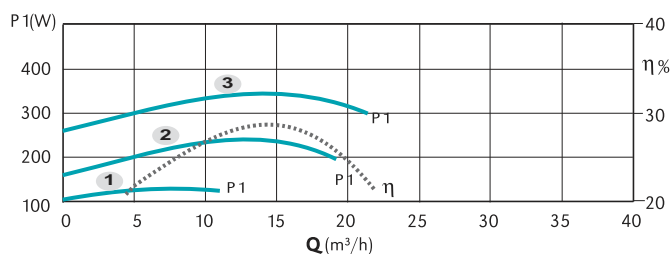
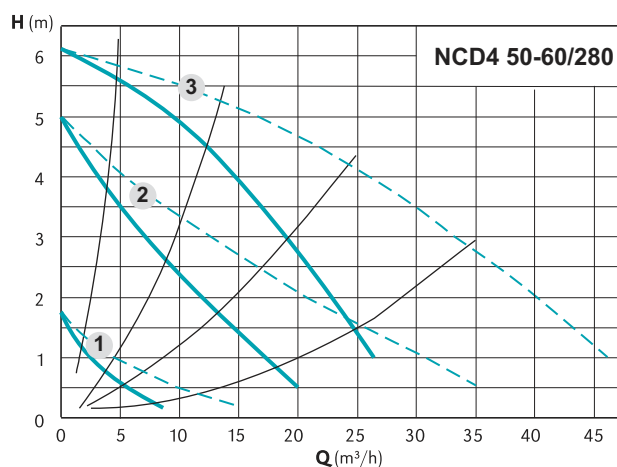
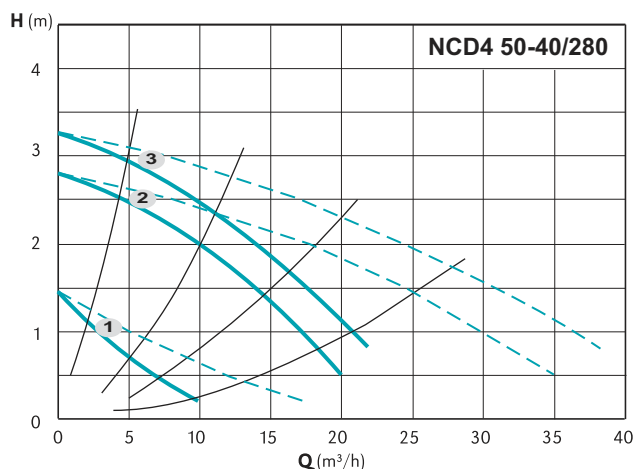

— Single operation
- - - Operation in parallel

— Single operation
- - - Operation in parallel

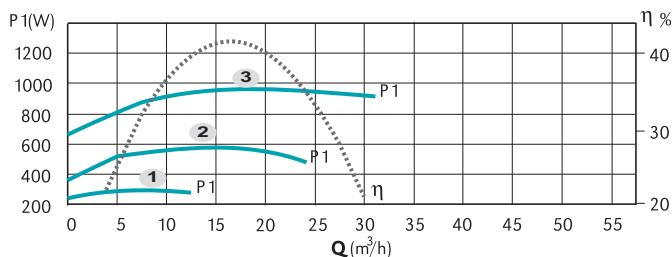
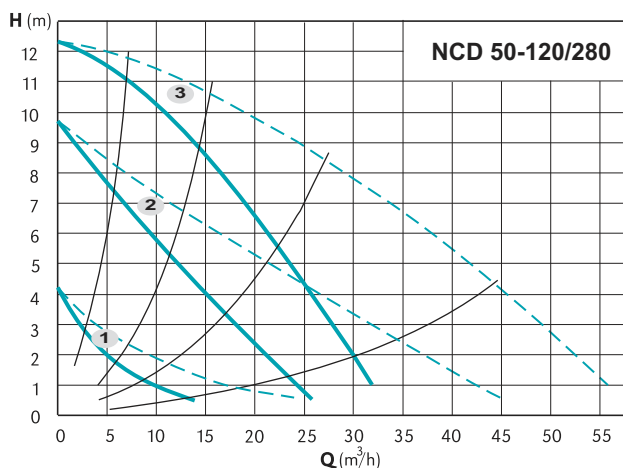

— Single operation
- - - Operation in parallel

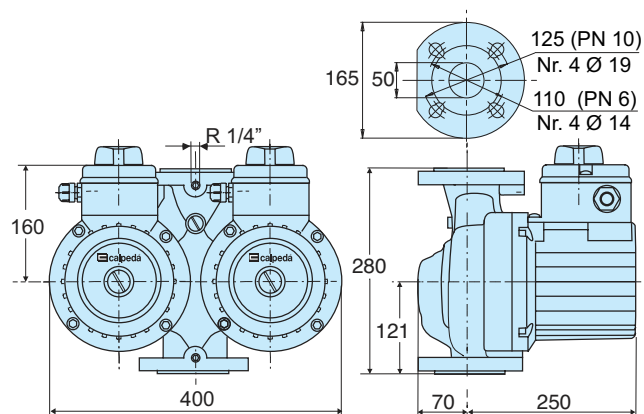

TYPE	DN	PN	N° Poli		Pos.	1/min	P1 (W)	3x 400 V [A]	[kg]
			2	4					
NCD4 50-40/280	50	6/10	✓	3	1450	340	1,05	44,0	
				2	1220	240	0,44		
				1	620	120	0,22		
NCD4 50-60/280	50	6/10	✓	3	1400	470	1,15	44,0	
				2	1000	300	0,55		
				1	560	100	0,20		
NCD 50-120/280	50	6/10	✓	3	2800	950	1,73	44,0	
				2	2330	540	1,05		
				1	1270	265	0,46		

Characteristic curves, dimensions and weights

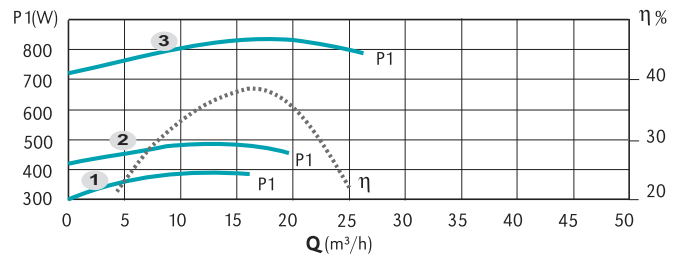
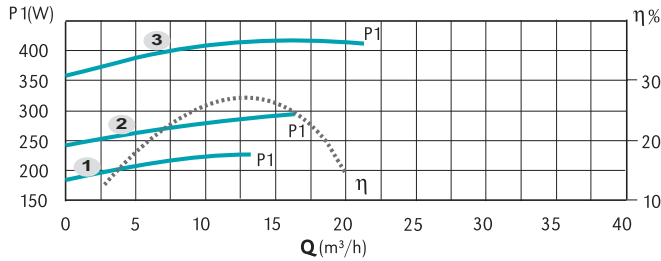
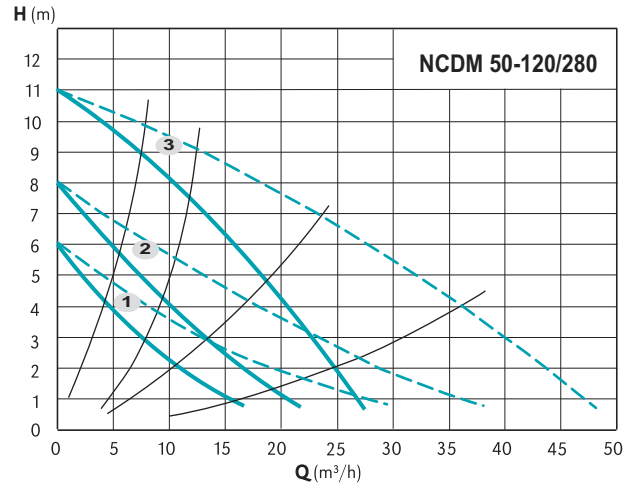
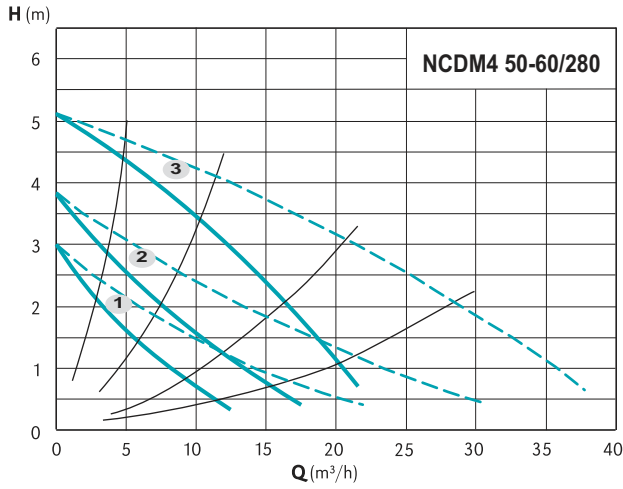

— Single operation
- - - Operation in parallel

— Single operation
- - - Operation in parallel

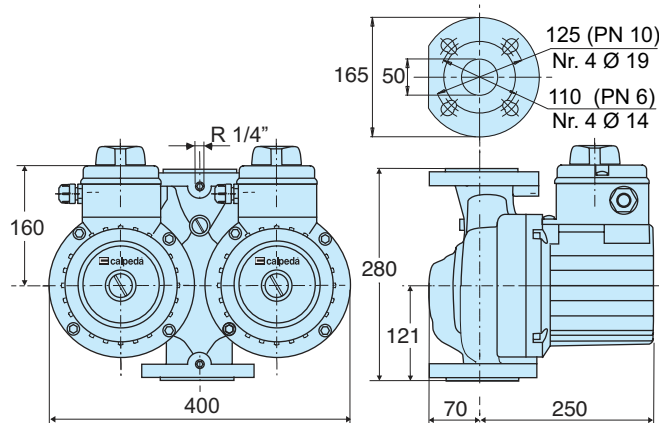

TYPE	DN	PN	N° Poli		Pos.	1/min	P1 (W)	1x 230 V [A]	[kg]
			2	4					
NCDM4 50-60/280	50	6/10	✓		3	1260	415	1,8	44,0
					2	1030	300	1,3	
					1	740	230	1,0	
NCDM 50-120/280	50	6/10	✓		3	2720	830	3,6	44,0
					2	1870	480	2,1	
					1	1450	390	1,7	

Characteristic curves, dimensions and weights

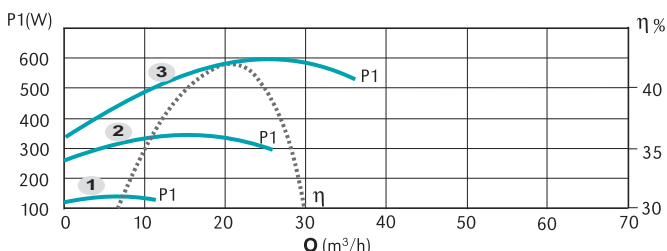
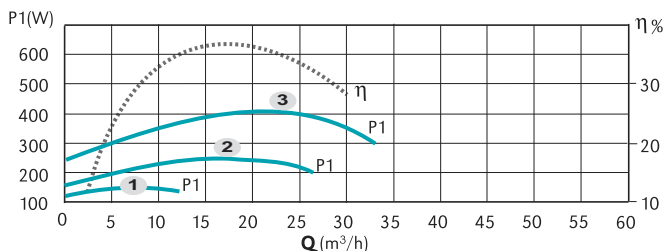
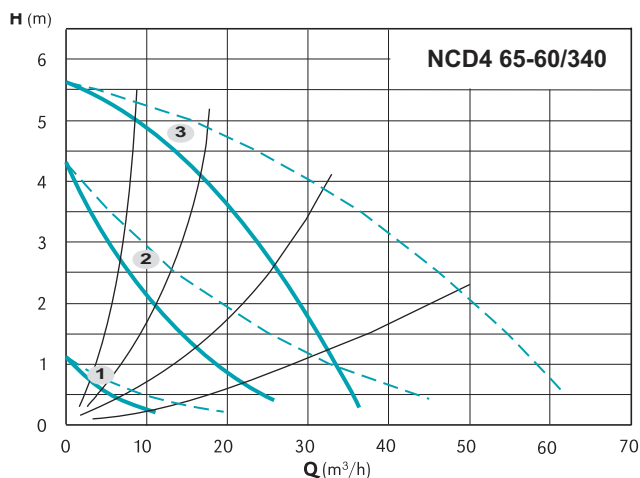
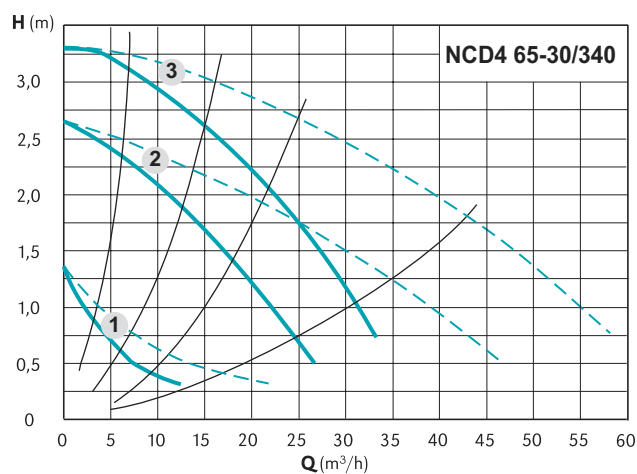

— Single operation
- - - Operation in parallel

— Single operation
- - - Operation in parallel

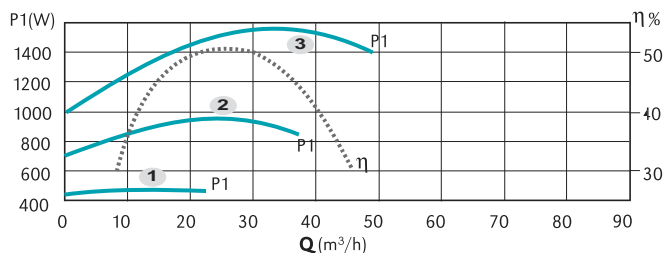
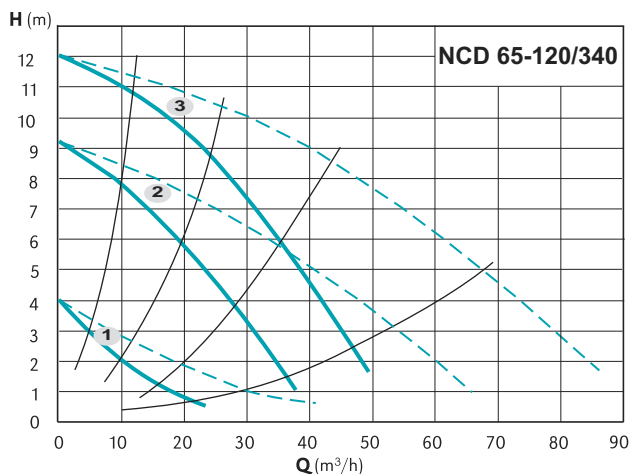

— Single operation
- - - Operation in parallel

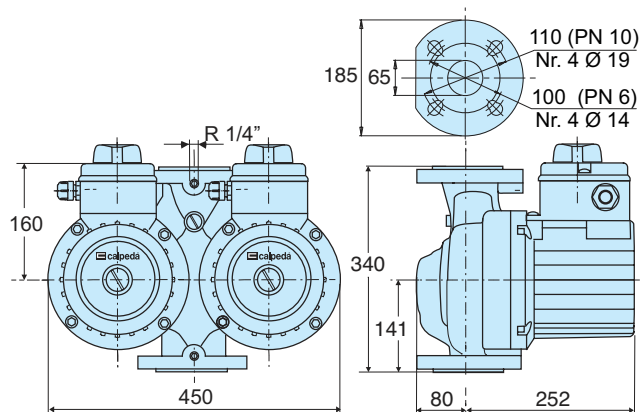

TYPE	DN	PN	N° Poli		Pos.	1/min	P1 (W)	3x 400 V [A]	[kg]
			2	4					
NCD4 65-30/340	65	6/10	✓		3	1430	400	1,10	49,0
					2	1150	260	0,50	
					1	600	120	0,22	
NCD4 65-60/340	65	6/10	✓		3	1370	600	1,25	49,0
					2	950	360	0,64	
					1	450	120	0,22	
NCD 65-120/340	65	6/10	✓		3	2810	1560	2,80	54,0
					2	2200	960	1,70	
					1	1250	460	0,84	

Characteristic curves, dimensions and weights

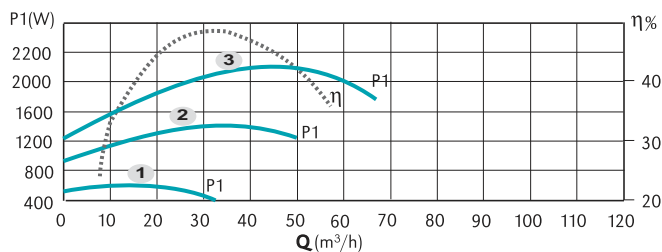
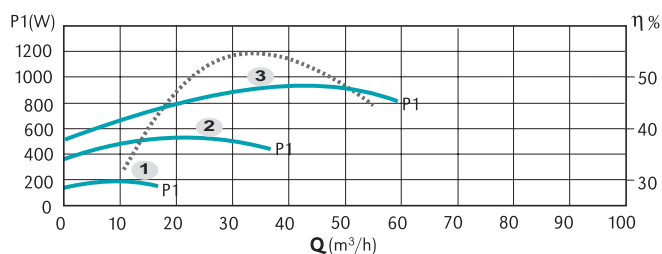
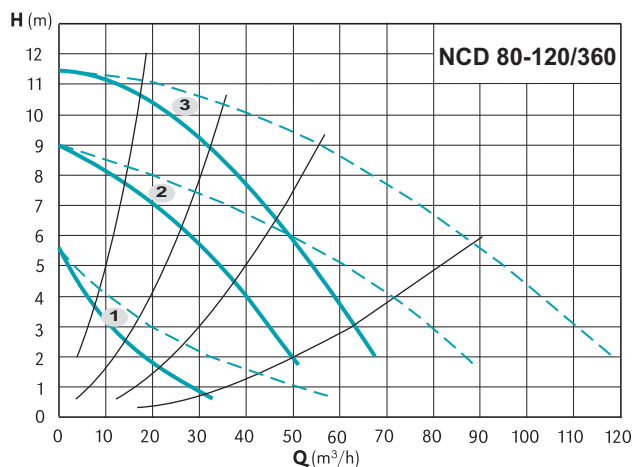
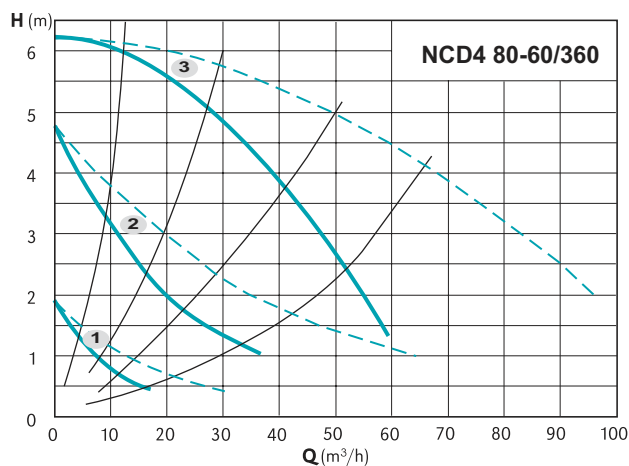

Single operation
 Operation in parallel

Single operation
 Operation in parallel

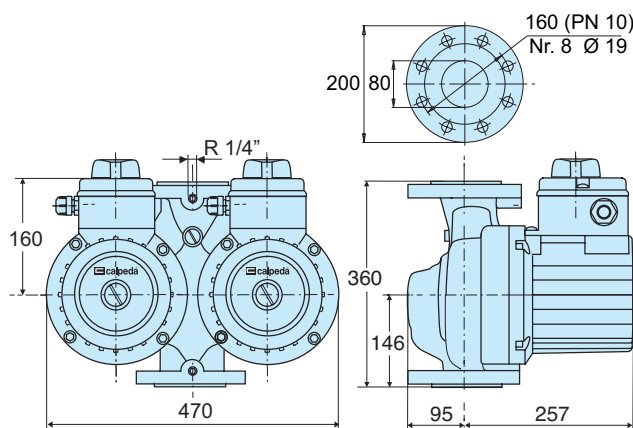

TYPE	DN	PN	N° Poli 2 / 4	Pos.	1/min	P1 (W)	3x 400 V [A]	[kg]
NCD4 80-60/360	80	10	✓	3	1350	960	2,20	60,0
				2	1000	560	1,10	
				1	600	200	0,38	
NCD 80-120/360	80	10	✓	3	2800	2200	3,80	62,0
				2	2160	1400	2,40	
				1	1200	550	1,05	